

## Introduction

The GT-AI transducer is a 3-way isolating analog signal re-scaling module with one input/output channel. It will accept one analog voltage or current input signal, isolates it and re-scales it to another voltage or current output signal. The I/O signals have several pre-calibrated fixed ranges or may be custom calibrated for various offsets and spans and can be direct or reverse acting to provide signal inversion.

The device has an on-board transformer that provides power supply isolation and also input/output signal isolation.

The GT-AI also includes a regulated +24 Vdc power output that can be used to power a transducer or a resistance input. It features top-adjust trim-pots for offset and gain control, source or sink capabilities and an LED power indicator. Various I/O signal types are easily selected with DIP switches.

The product comes with standard snap-track for easy mounting.

## Applications

- Isolated signal conversion or reversal
- Eliminate ground loop wiring problems
- Common-mode signal rejection
- Variable frequency motor drive signal isolation
- Electric actuator isolation
- Easily interface recorders, data loggers and controllers
- Interface and isolate DDC, EMS and HVAC panels

## Before Installation

Read these instructions carefully before installing and commissioning the GT-AI transducer. Failure to follow these instructions may result in product damage. Do not use in an explosive or hazardous environment, with combustible or flammable gases, as a safety or emergency stop device or in any other application where failure of the product could result in personal injury. Take electrostatic discharge precautions during installation and do not exceed the device ratings.

## Mounting

The snap-track device may be mounted in any position. Use only fingers to remove the pcb from the snap-track, do not pry on the pcb with tools. Do not flex the pcb during removal or installation. Slide the pcb out of the snap-track or push against one side of the snap-track and lift the pcb out. Ensure any metallic mounting hardware does not contact the underside of the pcb.

Avoid mounting in areas where the transducer is exposed to vibrations or rapid temperature changes.

## Wiring

Deactivate the 24 Vac power supply until all connections are made to the device to prevent electrical shock or equipment damage. Follow proper electrostatic discharge (ESD) handling procedures when installing the device or equipment damage may occur.

Use 22 AWG shielded wiring for all connections and do not locate the device wires in the same conduit with wiring used to supply inductive loads such as motors. Make all connections in accordance with national and local codes.

Connect the ac power supply to the two **AC** terminals. This is the input to the on-board transformer and has no other connection so it is a completely isolated supply.

Ensure the supplied power is within the device ratings as shown in the *Specifications* section of this document. Power supply voltages outside the ratings may cause over-heating, device damage or un-reliable operation.

The analog input signal is connected to the **IN+** and **IN-** terminals and the analog output signal is connected to the **OUT+** and **OUT-** terminals. The input and output signals are completely isolated from each other.

The **24V** terminal is a regulated power supply output which provides a 24 Vdc power supply at 30 mA maximum that can be used to power an external sensor, for example.

Study the wiring diagrams for proper connections with various input/output signal types and with both sinking or sourcing applications.

## Factory Configuration

The GT-AI is preset as follows:

- All DIP switches are set to off and must be configured for the correct signal type before use.
- REVERSE / NORMAL jumper is set for normal acting operation (output follows input).
- INPUT TYPE jumper set for VOLTAGE signal.
- OUTPUT TYPE jumpers set to VOLT and SOURCE.

## Device Setup

Follow the procedure from beginning to end to configure the GT-AI for the required signal types.

**Input Configuration**

Set the input jumpers:

For voltage input signal type set the input jumper to the **VOLT** (0-20 volt) position.

For current input signal type set the input jumper to either the **I\_LOW** (0-1 mA low current) or **I\_HIGH** (0-20 mA high current) position.

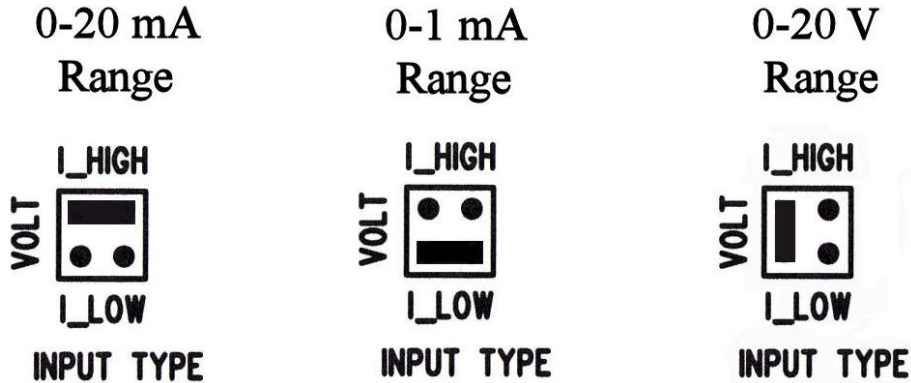

Set the input DIP switches:

If the required preset input signal type is listed in the table below, then set the 8 switches according to the chart and the input will be correctly calibrated for that signal type. For example, if the input signal is 0-1 V, then set switch 2 ON and all others OFF and the input will be correctly calibrated for the **0-1 V** range. The 0-1 V range setup is shown in the example picture.

| Input Signal Type | Input DIP Switch Settings |     |     |     |     |     |     |     |
|-------------------|---------------------------|-----|-----|-----|-----|-----|-----|-----|
|                   | 1                         | 2   | 3   | 4   | 5   | 6   | 7   | 8   |
| 0-1 V             | OFF                       | ON  | OFF | OFF | OFF | OFF | OFF | OFF |
| 0-5 V             | OFF                       | ON  | OFF | OFF | OFF | ON  | OFF | OFF |
| 0-10 V            | OFF                       | ON  | OFF | OFF | OFF | ON  | ON  | OFF |
| 0-15 V            | OFF                       | ON  | OFF | OFF | OFF | ON  | OFF | ON  |
| 0-20 V            | OFF                       | ON  | OFF | OFF | OFF | ON  | ON  | ON  |
| 1-5 V             | OFF                       | OFF | ON  | OFF | ON  | ON  | OFF | OFF |
| 2-10 V            | OFF                       | OFF | ON  | OFF | ON  | ON  | ON  | OFF |
| 3-15 V            | OFF                       | OFF | ON  | OFF | ON  | ON  | OFF | ON  |
| 4-20 V            | OFF                       | OFF | ON  | OFF | ON  | ON  | ON  | ON  |
| 0-1 mA            | OFF                       | ON  | OFF | OFF | OFF | OFF | OFF | OFF |
| 0-20 mA           | OFF                       | ON  | OFF | OFF | OFF | ON  | OFF | OFF |
| 4-20 mA           | OFF                       | OFF | ON  | OFF | ON  | ON  | OFF | OFF |

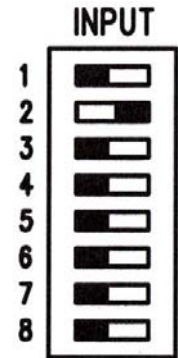

Select an adjustable input range:

If the required input signal is not listed in the chart above, then one of the adjustable ranges must be used. There are three adjustable ranges for voltage and one for current. Note that the minimum voltage span (maximum – minimum) is 1 volt and the minimum current span is 4 mA.

For voltage input, determine the maximum input signal and select the adjustable range accordingly. For example, if the input signal range will be 3-9 V then the maximum input will be 9 volts and the **Adj. 10 V max** range will be selected. Set the switches according to the chart below. For current input, set the switches according to the **Adj. 4-20 mA** range.

| Input Signal Type | Input DIP Switch Settings |     |     |       |     |    |     |     |
|-------------------|---------------------------|-----|-----|-------|-----|----|-----|-----|
|                   | 1                         | 2   | 3   | 4     | 5   | 6  | 7   | 8   |
| Adj. 5 V max      | ON                        | OFF | OFF | OFF * | OFF | ON | OFF | OFF |
| Adj. 10 V max     | ON                        | OFF | OFF | OFF * | OFF | ON | ON  | OFF |
| Adj. 20 V max     | ON                        | OFF | OFF | OFF * | OFF | ON | ON  | ON  |
| Adj. 4-20 mA      | ON                        | OFF | OFF | OFF * | OFF | ON | OFF | OFF |

To calibrate the adjustable ranges:

1. Configure the output signal type for 0-5 V by setting the output jumpers to **VOLT** and **SOURCE**. Then set the output DIP switches according to the Output DIP Switch Settings chart for the **0-5 V** preset range.
2. Ensure the input jumper is set to **VOLT** or **L\_HIGH** as required and that the input DIP switches are set according to the selected adjustable range.
3. Rotate the **MAX** pot fully counter-clockwise (the factory setting).
4. Connect 24 Vac power to the device and turn the power on.
5. If the input signal range starts at 0 V or 0 mA (such as 0-7 volts), then skip to step 7. If the input signal does not start at 0 V or 0 mA (such as 2-5 V), then continue to step 6 to calibrate the minimum signal.
6. Change the input DIP switch 4 setting from OFF to ON. Apply the minimum input signal. Measure the dc voltage from TP1 (+) to TP2 (-) on the pcb. Adjust the **MIN** pot to obtain 0 Vdc on the meter. The minimum value is now calibrated. Leave switch 4 in the ON position.
7. Connect a voltmeter to measure the output signal from **OUT +** to **OUT -**. Apply the maximum input signal and adjust the **MAX** pot until the meter reads 5.00 volts. The maximum value is now calibrated.

**Output Configuration**

The input must be configured before selecting the output configuration.

Set the output jumpers:

For voltage output signal type set the output jumpers to the **VOLT** (0-20 volt) and **SOURCE** positions.

For a sourcing current output signal type set the output jumpers to the **mA** (0-20 mA) and **SOURCE** position. For a sinking output current signal type, set the output jumpers to the **VOLT** and **SINK** positions.

The **NORM/REV** jumper should remain set in the **NORM** position until all other setting are made. If, for example, a 5-0 volt output is required then setup the device for a 0-5 volt output and then change the jumper to the **REV** position.

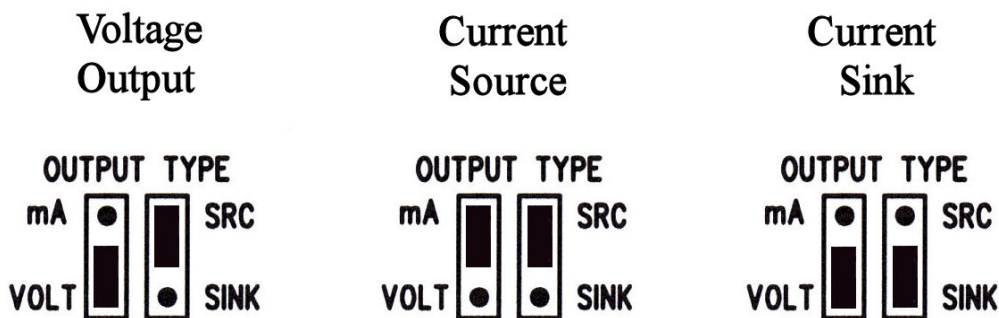

Set the output DIP switches:

If the required preset output signal type is listed in the table below, then set the 8 switches according to the chart and the output will be correctly calibrated for that signal type. For example, if the output signal is 4-20 mA, then set switches 4, 5, 6 and 8 ON and all others OFF and the input will be correctly calibrated for the **4-20 mA** output range. The 4-20 mA range setup is shown in the example picture.

| Output Signal Type | Output DIP Switch Settings |     |     |     |    |     |     |     |
|--------------------|----------------------------|-----|-----|-----|----|-----|-----|-----|
|                    | 1                          | 2   | 3   | 4   | 5  | 6   | 7   | 8   |
| 0-5 V              | ON                         | OFF | OFF | OFF | ON | OFF | ON  | ON  |
| 1-5 V              | OFF                        | OFF | OFF | ON  | ON | ON  | OFF | ON  |
| 0-10 V             | ON                         | OFF | OFF | OFF | ON | OFF | OFF | OFF |
| 2-10 V             | OFF                        | OFF | ON  | OFF | ON | OFF | OFF | ON  |
| 0-20 mA            | ON                         | OFF | OFF | OFF | ON | OFF | ON  | ON  |
| 4-20 mA            | OFF                        | OFF | OFF | ON  | ON | ON  | OFF | ON  |

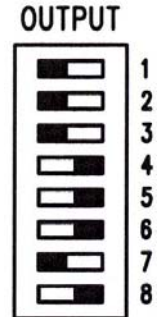

If the required output signal is not listed in the chart above, then one of the preset offset/span ranges could be used. Check the output signal requirements as follows; OFFSET = the minimum signal output, SPAN = maximum signal output minus minimum signal output.

For example, if the output signal is to be 0-7 volts, then OFFSET = 0 V and SPAN = 7 V. Once these two values are determined check the following charts for the available presets for offset and span.

Select a preset output offset:

If the OFFSET is 0, 1 or 2 volts or 0, 4 or 8 mA, then set the output DIP switches according to the following chart. Switches 5 to 8 will be set later for the SPAN.

| Output Signal Offset | Output DIP Switch Settings |     |     |     |   |   |   |   |
|----------------------|----------------------------|-----|-----|-----|---|---|---|---|
|                      | 1                          | 2   | 3   | 4   | 5 | 6 | 7 | 8 |
| 0 V or 0 mA          | ON                         | OFF | OFF | OFF | * | * | * | * |
| 1 V or 4 mA          | OFF                        | OFF | OFF | ON  | * | * | * | * |
| 2 V or 8 mA          | OFF                        | OFF | ON  | OFF | * | * | * | * |

Select an adjustable output offset:

If the required OFFSET is not equal to one of the preset values in the above chart, then select the adjustable offset as shown in the following chart. An example of this would be if the output signal is to be 3-15 volts, then OFFSET = 3 V and SPAN = 12 V.

| Output Signal Offset | Output DIP Switch Settings |    |     |     |   |   |   |   |
|----------------------|----------------------------|----|-----|-----|---|---|---|---|
|                      | 1                          | 2  | 3   | 4   | 5 | 6 | 7 | 8 |
| Adj. 0-10 V          | OFF                        | ON | OFF | OFF | * | * | * | * |
| Adj. 0-12 mA         | OFF                        | ON | OFF | OFF | * | * | * | * |

To calibrate the adjustable offset:

1. Ensure the **Input Configuration** section is completed first.
2. Set the output DIP switches 5-8 to the ON position.
3. Connect 24 Vac power to the device and turn the power on.

4. For voltage output signal type, connect a voltmeter to measure the output voltage signal from **OUT +** to **OUT -**. For current sourcing output signal type, connect a mA meter from **OUT +** to **OUT -** to measure the output current signal. For current sinking output, temporarily set the output to sourcing (and mA) and measure the output current as previously described, or measure the current at the **OUT +** terminal directly in sinking mode.
5. Apply the minimum input signal to the device input and then adjust the **OFFSET** pot for the correct minimum output. The output offset value is now calibrated.

Select a preset output span:

If the SPAN is 1, 3, 4, 5, 6, 7, 8 or 10 volts or 4, 12, 16 or 20 mA, then set the output DIP switches according to the following chart. Switches 1 to 4 have been set previously for the **OFFSET**. Remember, SPAN = maximum minus minimum.

| Output Signal Span | Output DIP Switch Settings |   |   |   |    |     |     |     |
|--------------------|----------------------------|---|---|---|----|-----|-----|-----|
|                    | 1                          | 2 | 3 | 4 | 5  | 6   | 7   | 8   |
| 1 V or 4 Ma        | *                          | * | * | * | ON | ON  | ON  | ON  |
| 3 V or 12 mA       | *                          | * | * | * | ON | ON  | ON  | OFF |
| 4 V or 16 mA       | *                          | * | * | * | ON | ON  | OFF | ON  |
| 5 V or 20 mA       | *                          | * | * | * | ON | OFF | ON  | ON  |
| 6 V                | *                          | * | * | * | ON | ON  | OFF | OFF |
| 7 V                | *                          | * | * | * | ON | OFF | ON  | OFF |
| 8 V                | *                          | * | * | * | ON | OFF | OFF | ON  |
| 10 V               | *                          | * | * | * | ON | OFF | OFF | OFF |

Select an adjustable output span:

If the required SPAN is not equal to one of the preset values in the above chart, then select the adjustable span as shown in the following chart. An example of this would be if the output signal is to be 3-15 volts, then **OFFSET** = 3 V and **SPAN** = 12 V. In this case, since **SPAN** = 12 V, select the **Adj. 10-20 V** option.

| Output Signal Span | Output DIP Switch Settings |   |   |   |     |     |     |     |
|--------------------|----------------------------|---|---|---|-----|-----|-----|-----|
|                    | 1                          | 2 | 3 | 4 | 5   | 6   | 7   | 8   |
| Adj. 1-10 V        | *                          | * | * | * | OFF | ON  | ON  | ON  |
| Adj. 10-20 V       | *                          | * | * | * | OFF | OFF | OFF | OFF |
| Adj. 4-20 mA       | *                          | * | * | * | OFF | ON  | ON  | ON  |

To calibrate the adjustable span:

1. Ensure the **Input Configuration** section is completed first.
2. Ensure the output DIP switches 1-4 have been set previously for the offset.
3. Connect 24 Vac power to the device and turn the power on.
4. For voltage output signal type, connect a voltmeter to measure the output voltage signal from **OUT +** to **OUT -**. For current sourcing output signal type, connect a mA meter from **OUT +** to **OUT -** to measure the output current signal. For current sinking output, temporarily set the output to sourcing (and mA) and measure the output current as previously described, or measure the current at the **OUT +** terminal directly in sinking mode.
5. Apply the maximum input signal to the device input and then adjust the **SPAN** pot for the correct maximum output. The output span value is now calibrated.

Reversing the output signal:

If the required output signal is to be reversed, then simply move the **NORM/REV** jumper from the **NORM** position to the **REV** position. This will allow, for example, an input signal of 0-5 V and an output signal of 5-0 V.

**General Specifications**

Power Supply . . . . . 24 Vac  $\pm$  10%  
Consumption . . . . . 150 mA maximum  
Operating Conditions . . . . . 0 to 50 °C (32 to 122 °F), 5 to 95 %RH non-condensing  
Storage Conditions . . . . . -30 to 70 °C (-22 to 158 °F), 5 to 95 %RH non-condensing  
Wiring Connections . . . . . Screw terminal block (12 to 24 AWG)  
Weight . . . . . 285 gm (10 oz)  
Enclosure . . . . . Snap track mounting standard, 5.0" long x 3.25" wide x 1.85" high (127 x 82.5 x 47 mm)

**Power Output**

Regulated Power Output . . . . . 24 Vdc  $\pm$  10% @ 30 mA maximum (use to power an external sensor)

**Input Signal**

Preset Voltage Ranges . . . . . 0-1, 0-5, 0-10, 0-15, 0-20, 1-5, 2-10, 3-15 and 4-20 Vdc  
Adjustable Voltage Offset . . . . . 0-20 Vdc  
Adjustable Voltage Span . . . . . 1-20 Vdc  
Input Voltage Impedance . . . . . > 10 K $\Omega$

Preset Current Ranges . . . . . 0-1, 0-20 and 4-20 mA  
Adjustable Current Offset . . . . . 0-15 mA  
Adjustable Current Span . . . . . 4-20 mA  
Input Current Impedance . . . . . 250  $\Omega$  (1 K $\Omega$  for 0-1 mA range)

Current Signal Type . . . . . Source or Sink (use regulated power output terminal)

**Output Signal**

Preset Voltage Ranges . . . . . 0-5, 1-5, 0-10 and 2-10 Vdc  
Preset Voltage Offsets . . . . . 0, 1 and 2 Vdc  
Preset Voltage Spans . . . . . 1, 3, 4, 5, 6, 7, 8 and 10 Vdc  
Adjustable Voltage Offset . . . . . 0-10 Vdc  
Adjustable Voltage Span . . . . . 1-20 Vdc  
Output Voltage Impedance . . . . . 5 K $\Omega$  minimum

Preset Current Ranges . . . . . 0-20 and 4-20 mA  
Preset Current Offsets . . . . . 0, 4 and 8 mA  
Preset Current Spans . . . . . 4, 12, 16 and 20 mA  
Adjustable Current Offset . . . . . 0-12 mA  
Adjustable Current Span . . . . . 4-20 mA  
Output Current Impedance . . . . . 750  $\Omega$  maximum

Current Signal Type . . . . . Source or Sink (jumper selectable)  
Signal Direction . . . . . Normal / Reversible via single jumper  
Accuracy . . . . .  $\pm$  1 % typical

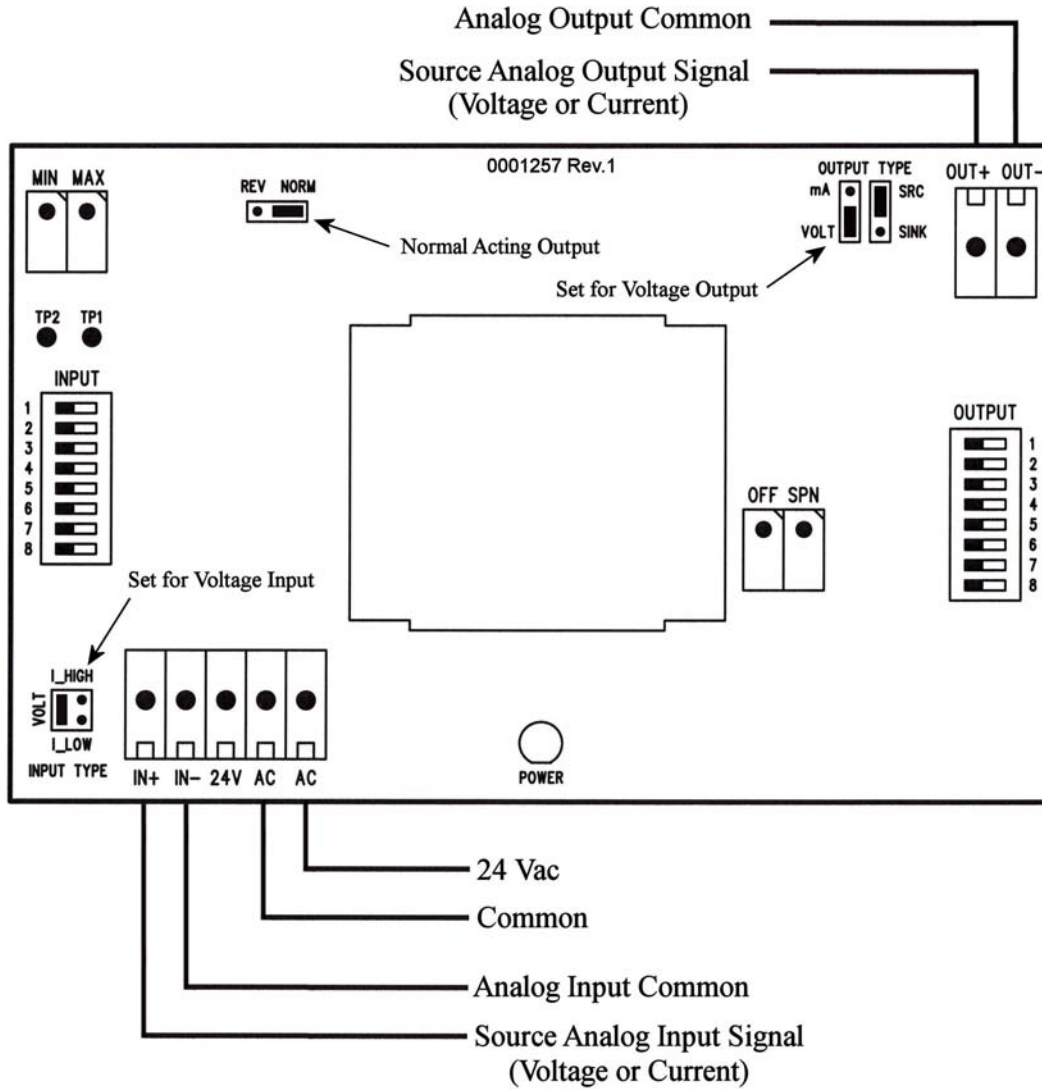

Input from a 2-Wire Current Loop Powered Sensor

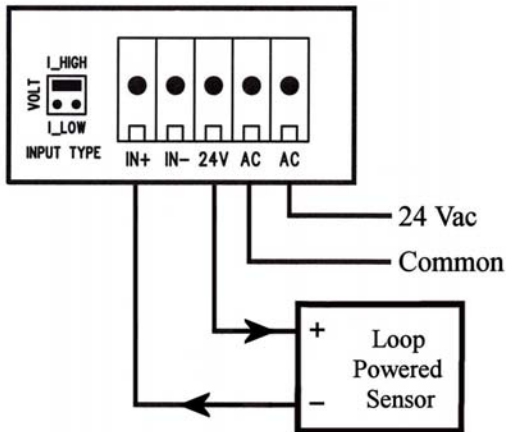

Current Sink Output

